

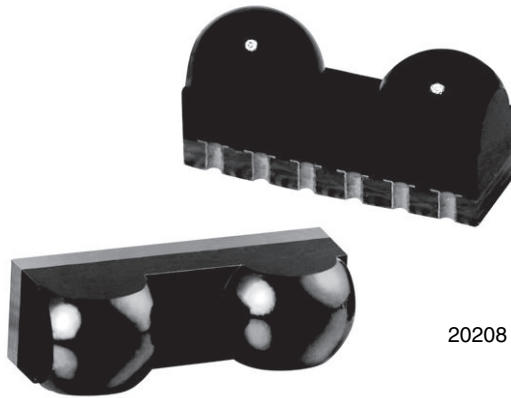

Infrared Transceiver Module (SIR, 115.2 kbit/s) for IrDA® Applications



DESCRIPTION

TFBS4711 is an infrared transceiver that supports data rates up to 115 kbit/s per the IrDA standard. The link distance is up to 1 meter. The transceiver includes a PIN photodiode, an infrared emitter, and a low power control IC. These components have not been qualified according to automotive specifications.

FEATURES

- Compliant to the IrDA physical layer specification
- Standard IrDA link distance of 1 m
- Low power consumption, typically less than 70 μ A
- Less than 1 μ A in shutdown mode
- Material categorization:
for definitions of compliance please see www.vishay.com/doc?99912



RoHS
COMPLIANT
HALOGEN
FREE
GREEN
(5-2008)

APPLICATIONS

- Short-distance wireless communication and data transfer
- Use in environments where RF is problematic

LINKS TO ADDITIONAL RESOURCES



DESIGN SUPPORT TOOLS

- [3D model](#)
- [Window size calculator](#)
- [Symbols and terminology](#)
- [IRDC protocol](#)
- [Reference layouts and circuit diagrams](#)

FUNCTIONAL BLOCK DIAGRAM

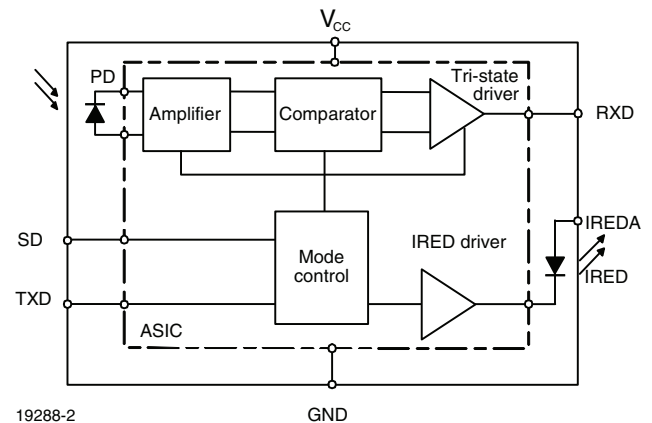



PRODUCT SUMMARY					
PART NUMBER	DATA RATE (kbit/s)	DIMENSIONS H x L x W (mm)	LINK DISTANCE (m)	OPERATING VOLTAGE (V)	IDLE SUPPLY CURRENT (mA)
TFBS4711	115.2	1.9 x 6 x 3	0 to ≥ 1	2.4 to 5.5	0.07

PARTS TABLE		
PART NUMBER	DESCRIPTION	QTY/REEL
TFBS4711-TR1	Oriented in carrier tape for side view surface mounting	1000 pcs
TFBS4711-TR3	Oriented in carrier tape for side view surface mounting	2500 pcs
TFBS4711-TT1	Oriented in carrier tape for top view surface mounting	1000 pcs

PINOUT

TFBS4711
weight 43 mg

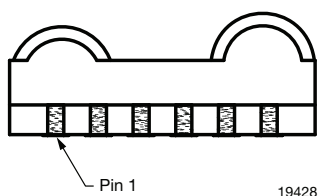

PIN DESCRIPTION				
PIN NUMBER	SYMBOL	DESCRIPTION	I/O	ACTIVE
1	V _{CC2} IRED anode	Connect IRED anode directly to the power supply (V _{CC2}). IRED current can be decreased by adding a resistor in series between the power supply and IRED anode. A separate unregulated power supply can be used at this pin		
2	TXD	This Schmitt-Trigger input is used to transmit serial data when SD is low. An on-chip protection circuit disables the LED driver if the TXD pin is asserted for longer than 100 μs. The input threshold voltage adapts to and follows the logic voltage swing defined by the applied supply voltage	I	High
3	RXD	Received data output, push-pull CMOS driver output capable of driving standard CMOS or TTL loads. During transmission the RXD output is active and mirrors the transmit signal. No external pull-up or pull-down resistor is required. Floating with a weak pull-up of 500 kΩ (typ.) in shutdown mode. The voltage swing is defined by the applied supply voltage	O	Low
4	SD	Shutdown. The input threshold voltage adapts to and follows the logic voltage swing defined by the applied supply voltage	I	High
5	V _{CC1}	Supply voltage		
6	GND	Ground		



ABSOLUTE MAXIMUM RATINGS						
PARAMETER	TEST CONDITIONS	SYMBOL	MIN.	TYP.	MAX.	UNIT
Supply voltage range, transceiver	$-0.3\text{ V} < V_{CC2} < 6\text{ V}$	V_{CC1}	-0.5	-	+6	V
Supply voltage range, transmitter	$-0.5\text{ V} < V_{CC1} < 6\text{ V}$	V_{CC2}	-0.5	-	+6	V
RXD output voltage	$-0.5\text{ V} < V_{CC1} < 6\text{ V}$	V_{RXD}	-0.5	-	$V_{CC1} + 0.5$	V
Voltage at all inputs	Note: $V_{in} \geq V_{CC1}$ is allowed	V_{in}	-0.5	-	+6	V
Input current	For all pins except IRED anode pin	I_{CC}	-	-	10	mA
Output sink current			-	-	25	mA
Power dissipation		P_D	-	-	250	mW
Junction temperature		T_j	-	-	125	°C
Ambient temperature range (operating)		T_{amb}	-25	-	+85	°C
Storage temperature range		T_{stg}	-25	-	+85	°C
Soldering temperature	See recommended solder profile		-	-	260	°C
Average output current, pin 1		$I_{RED} (DC)$	-	-	85	mA
Repetitive pulsed output current pin 1 to pin 2	JESD22-A114	$I_{RED} (RP)$	-	-	430	mA
ESD protection	JESD78	V_{ESD}	2	-	-	kV
Latchup			± 100	-	-	mA
Thermal resistance junction to ambient	JESD51	R_{thJA}	-	300	-	K/W

Note

- Reference point ground, pin 6 unless otherwise noted. Typical values are for design aid only, not guaranteed nor subject to production testing.

EYE SAFETY INFORMATION	
STANDARD	CLASSIFICATION
IEC/EN 60825-1 (2007-03), DIN EN 60825-1 (2008-05) "SAFETY OF LASER PRODUCTS - Part 1: equipment classification and requirements", simplified method	Class 1
IEC 62471 (2006), CIE S009 (2002) "Photobiological Safety of Lamps and Lamp Systems"	Exempt
DIRECTIVE 2006/25/EC OF THE EUROPEAN PARLIAMENT AND OF THE COUNCIL of 5 th April 2006 on the minimum health and safety requirements regarding the exposure of workers to risks arising from physical agents (artificial optical radiation) (19 th individual directive within the meaning of article 16(1) of directive 89/391/EEC)	Exempt

Note

- Vishay transceivers operating inside the absolute maximum ratings are classified as eye safe according the above table



ELECTRICAL CHARACTERISTICS ($T_{amb} = 25\text{ }^{\circ}\text{C}$, $V_{CC1} = V_{CC2} = 2.4\text{ V to } 5.5\text{ V}$ unless otherwise noted)						
PARAMETER	TEST CONDITIONS	SYMBOL	MIN.	TYP.	MAX.	UNIT
TRANSCEIVER						
Supply voltage		V_{CC1}	2.4	-	5.5	V
Data rates			9.6	-	115.2	kbit/s
Idle supply current at V_{CC1} (receive mode, no signal)	SD = low, $T_{amb} = -25\text{ }^{\circ}\text{C to } +85\text{ }^{\circ}\text{C}$ independent of ambient light, $V_{CC1} = V_{CC2} = 2.4\text{ V to } 5.5\text{ V}$	I_{CC1}	40	70	150	μA
Average dynamic supply current, transmitting	$I_{RED} = 300\text{ mA}$, 20 % duty cycle	I_{CC1}	-	0.6	2	mA
Standby (SD) ⁽¹⁾ supply current	SD = high, $T_{amb} = -25\text{ }^{\circ}\text{C to } +85\text{ }^{\circ}\text{C}$, independent of ambient light	I_{SD}	-	0.01	1	μA
RXD to V_{CC1} impedance	SD = high	R_{RXD}	400	500	600	k Ω
Input voltage low (TXD, SD)		V_{ILo}	-0.3	-	0.4	V
Input voltage high (SD)	For compliance with I_{SD} spec.	V_{IHHi}	$V_{CC1} - 0.3$	-	6	V
Input voltage high (TXD)		V_{IHHi}	$V_{CC1} - 0.5$	-	6	V
Input leakage current low	$V_{ILo} \leq 0.3\text{ V}$	I_{ILo}	-	0.01	10	μA
Input leakage current high	$V_{IHHi} \geq V_{CC1} - 0.3\text{ V}$	I_{IHHi}	-	0.01	10	μA
Input capacitance (TXD, SD)		C_{IN}	-	-	5	pF
Output voltage low, RXD	$C_{load} = 8\text{ pF}$, $I_{OLo} \leq +500\text{ }\mu\text{A} $	V_{OLo}	-	-	$0.15 \times V_{CC1}$	V
Output voltage high, RXD	$I_{OH} = -200\text{ }\mu\text{A}$	V_{OHi}	$0.8 \times V_{CC1}$	-	-	V

Notes

- Typical values are for design aid only, not guaranteed nor subject to production testing
- (1) SD mode becomes active when SD is set high for more than 0.2 μs . In SD mode the detector is disabled and the output disconnected

OPTOELECTRONIC CHARACTERISTICS ($T_{amb} = 25\text{ }^{\circ}\text{C}$, $V_{CC1} = V_{CC2} = 2.4\text{ V to } 5.5\text{ V}$ unless otherwise noted)						
PARAMETER	TEST CONDITIONS	SYMBOL	MIN.	TYP.	MAX.	UNIT
RECEIVER						
Minimum irradiance E_e in angular range ⁽²⁾	9.6 kbit/s to 115.2 kbit/s $\lambda = 850\text{ nm to } 900\text{ nm}$, $\alpha = 0^{\circ}, 15^{\circ}$	E_e	-	35	80	mW/m^2
Maximum irradiance E_e in angular range ⁽³⁾	$\lambda = 850\text{ nm to } 900\text{ nm}$	E_e	2	5	-	kW/m^2
Maximum no detection irradiance ⁽¹⁾	$\lambda = 850\text{ nm to } 900\text{ nm}$, $t_r, t_f < 40\text{ ns}$, $t_{po} = 1.6\text{ }\mu\text{s}$ at $f = 115\text{ kHz}$, no output signal allowed	E_e	4	-	-	mW/m^2
Rise time of output signal	10 % to 90 %, $C_L = 8\text{ pF}$	$t_{r(RXD)}$	10	30	80	ns
Fall time of output signal	90 % to 10 %, $C_L = 8\text{ pF}$	$t_{f(RXD)}$	10	30	80	ns
RXD pulse width of output signal	Input pulse length $> 1.2\text{ }\mu\text{s}$	t_{PW}	1.7	2.2	3	μs
Stochastic jitter, leading edge	Input irradiance = 100 mW/m^2 , $\leq 115.2\text{ kbit/s}$		-	-	350	ns
Standby/shutdown delay, receiver startup time	After shutdown active or power-on		-	100	500	μs
Latency		t_L	-	50	150	μs



OPTOELECTRONIC CHARACTERISTICS (T _{amb} = 25 °C, V _{CC1} = V _{CC2} = 2.4 V to 5.5 V unless otherwise noted)						
PARAMETER	TEST CONDITIONS	SYMBOL	MIN.	TYP.	MAX.	UNIT
TRANSMITTER						
IRED operating current limitation	No external resistor for current limitation ⁽⁵⁾	I _D	200	300	430	mA
Forward voltage of built-in IRED	I _F = 300 mA	V _f	1.4	1.8	1.9	V
Output leakage IRED current	TXD = 0 V, 0 < V _{CC1} < 5.5 V	I _{IRED}	-1	0.01	1	µA
Output radiant intensity	α = 0°, 15° TXD = high, SD = low	I _e	40	140	300	mW/sr
	V _{CC1} = 5 V, α = 0°, 15°, TXD = low or SD = high (receiver is inactive as long as SD = high)	I _e	-	-	0.04	mW/sr
Output radiant intensity, angle of half intensity		α	-	± 24	-	deg
Peak-emission wavelength ⁽⁵⁾		λ _p	870	-	910	nm
Spectral bandwidth		Δλ	-	45	-	nm
Optical rise time		t _{ropt}	10	50	300	ns
Optical fall time		t _{fopt}	10	50	300	ns
Optical output pulse duration	Input pulse width 1.6 < t _{TXD} < 23 µs	t _{opt}	t _{TXD} - 0.15	-	t _{TXD} + 0.15	µs
	Input pulse width t _{TXD} ≥ 23 µs	t _{opt}	23	50	100	µs
Optical overshoot			-	-	25	%

Notes

- Typical values are for design aid only, not guaranteed nor subject to production testing
- (1) Equivalent to IrDA background light and electromagnetic field test: fluorescent lighting immunity
- (2) IrDA sensitivity definition: minimum irradiance E_e in angular range, power per unit area. The receiver must meet the BER specification while the source is operating at the minimum intensity in angular range into the minimum half-angular range at the maximum link length
- (3) Maximum irradiance E_e in angular range, power per unit area. The optical delivered to the detector by a source operating at the maximum intensity in angular range at minimum link length must not cause receiver overdrive distortion and possible related link errors. If placed at the active output interface reference plane of the transmitter, the receiver must meet its bit error ratio (BER). For more definitions see the document "Symbols and Terminology" on the Vishay website
- (4) Using an external current limiting resistor is allowed and recommended to reduce IRED intensity and operating current when current reduction is intended to operate at the IrDA low power conditions. E.g. for V_{CC2} = 3.3 V a current limiting resistor of R_S = 56 Ω will allow a power minimized operation at IrDA low power conditions
- (5) Due to this wavelength restriction compared to the IrDA spec of 850 nm to 900 nm the transmitter is able to operate as source for the standard remote control applications with codes as e.g. Philips RC5/RC6® or RECS 80

RECOMMENDED CIRCUIT DIAGRAM

Operated with a clean low impedance power supply the TFBS4711 needs no additional external components. However, depending on the entire system design and board layout, additional components may be required (see Fig. 1).

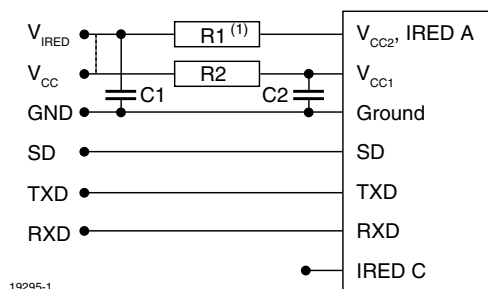

Fig. 1 - Recommended Application Circuit

Note

- (1) R1 is optional when reduced intensity is used

The capacitor C1 is buffering the supply voltage and eliminates the inductance of the power supply line. This one should be a tantalum or other fast capacitor to guarantee the fast rise time of the IRED current. The resistor R1 is the current limiting resistor, which may be used to reduce the operating current to levels below the specified controlled values for saving battery power.

Vishay's transceivers integrate a sensitive receiver and a built-in power driver. The combination of both needs a careful circuit board layout. The use of thin, long, resistive and inductive wiring should be avoided. The shutdown input must be grounded for normal operation, also when the shutdown function is not used.

TABLE 1 - RECOMMENDED APPLICATION CIRCUIT COMPONENTS	
COMPONENT	RECOMMENDED VALUE
C1	4.7 µF
C2	0.1 µF, ceramic
R1	Depends on current to be adjusted
R2	47 Ω



The inputs (TXD, SD) and the output RXD should be directly connected (DC - coupled) to the I/O circuit. The capacitor C2 combined with the resistor R2 is the low pass filter for smoothing the supply voltage. R2, C1 and C2 are optional and dependent on the quality of the supply voltages V_{CC1} and injected noise. An unstable power supply with dropping voltage during transmission may reduce the sensitivity (and transmission range) of the transceiver.

The placement of these parts is critical. It is strongly recommended to position C2 as close as possible to the transceiver pins.

When extended wiring is used as in bench tests the inductance of the power supply can cause dynamically a voltage drop at V_{CC2} . Often some power supplies are not able to follow the fast current rise time. In that case another 4.7 μF (type, see table under C1) at V_{CC2} will be helpful.

Under extreme EMI conditions as placing an RF-transmitter antenna on top of the transceiver, we recommend to protect all inputs by a low-pass filter, as a minimum a 12 pF capacitor, especially at the RXD port.

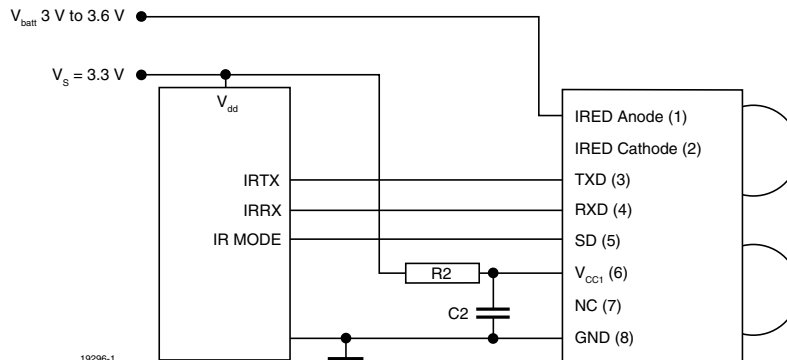

Fig. 2 - Typical Application Circuit

Figure 2 shows an example of a typical application for to work with a separate supply voltage V_s and using the transceiver with the IRED Anode connected to the unregulated battery V_{batt} . This method reduces the peak load of the regulated power supply and saves therefore costs. Alternatively all supplies can also be tied to only one voltage source. R1 and C1 are not used in this case and are depending on the circuit design in most cases not necessary.

I/O AND SOFTWARE

In the description, already different I/Os are mentioned. Different combinations are tested and the function verified with the special drivers available from the I/O suppliers. In special cases refer to the I/O manual, the Vishay application notes, or contact directly Vishay Sales, Marketing or Application.

For operating at RS232 ports the ENDECS TIR1000 or MCP2122 is recommended.

Note

- TFBS4711 echoes the TXD signal at the RXD output during transmission. For communication this signal is to be correctly ignored by the controller or the software. The echo signal is implemented for test purposes in mass production



TABLE 2 - TRUTH TABLE					
INPUTS			OUTPUTS		REMARK
SD	TXD	OPTICAL INPUT IRRADIANCE mW/m ²	RXD	TRANSMITTER	OPERATION
High > 1 ms	x	x	Weakly pulled (500 kΩ) to V _{CC1}	0	Shutdown
Low	High	x	Low (active)	I _e	Transmitting
Low	High > 100 μs	x	High inactive	0	Protection is active
Low	Low	< 4	High inactive	0	Ignoring low signals below the IrDA defined threshold for noise immunity
Low	Low	> min. detection threshold irradiance < max. detection threshold irradiance	Low (active)	0	Response to an IrDA compliant optical input signal
Low	Low	> min. detection threshold irradiance	Undefined	0	Overload conditions can cause unexpected outputs

ASSEMBLY INSTRUCTIONS

Reflow Soldering

- Reflow soldering must be done within 72 h while stored under a max. temperature of 30 °C, 60 % RH after opening the dry pack envelope
- Set the furnace temperatures for pre-heating and heating in accordance with the reflow temperature profile as shown in the diagram. Exercise extreme care to keep the maximum temperature below 260 °C. The temperature shown in the profile means the temperature at the device surface. Since there is a temperature difference between the component and the circuit board, it should be verified that the temperature of the device is accurately being measured
- Handling after reflow should be done only after the work surface has been cooled off

Manual Soldering

- Use a soldering iron of 25 W or less. Adjust the temperature of the soldering iron below 300 °C
- Finish soldering within 3 s
- Handle products only after the temperature has cooled off

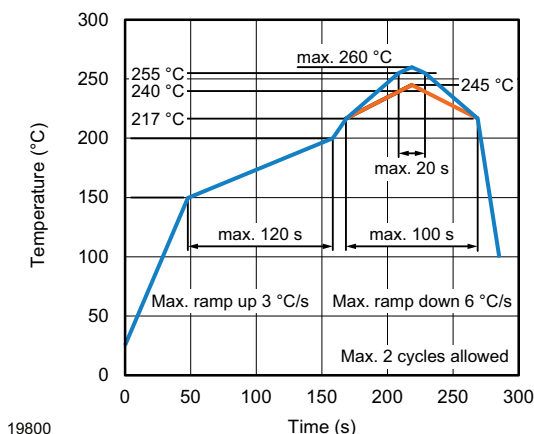



PACKAGE DIMENSIONS in millimeters

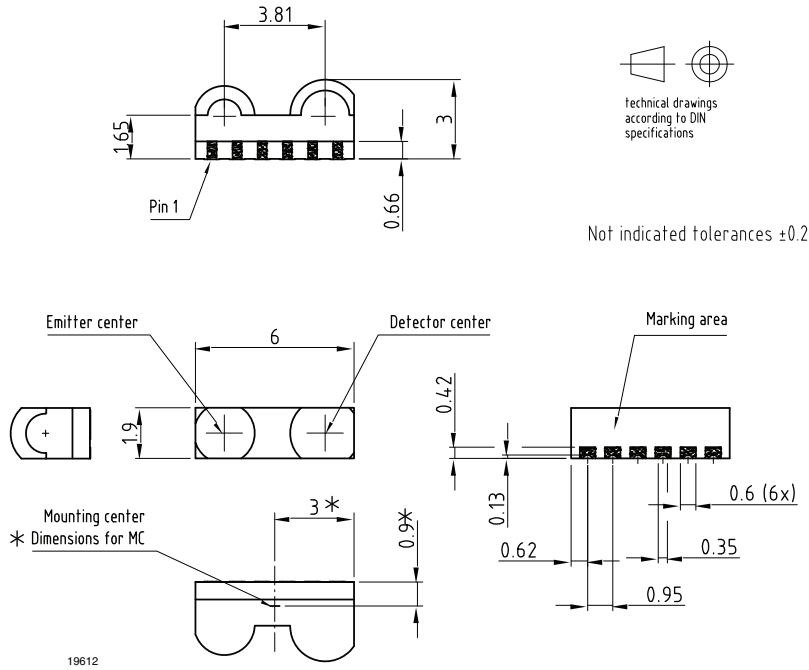

Fig. 3 - Package Drawing of TFBS4711, Tolerance of Height is +0.1 mm, -0.2 mm, other Tolerances ± 0.2 mm

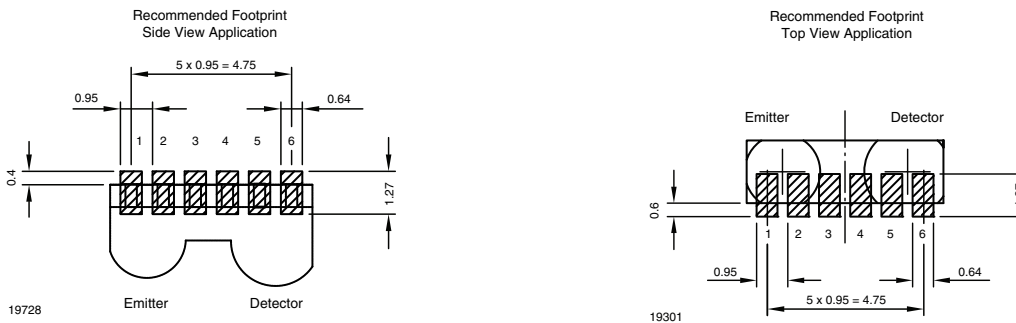
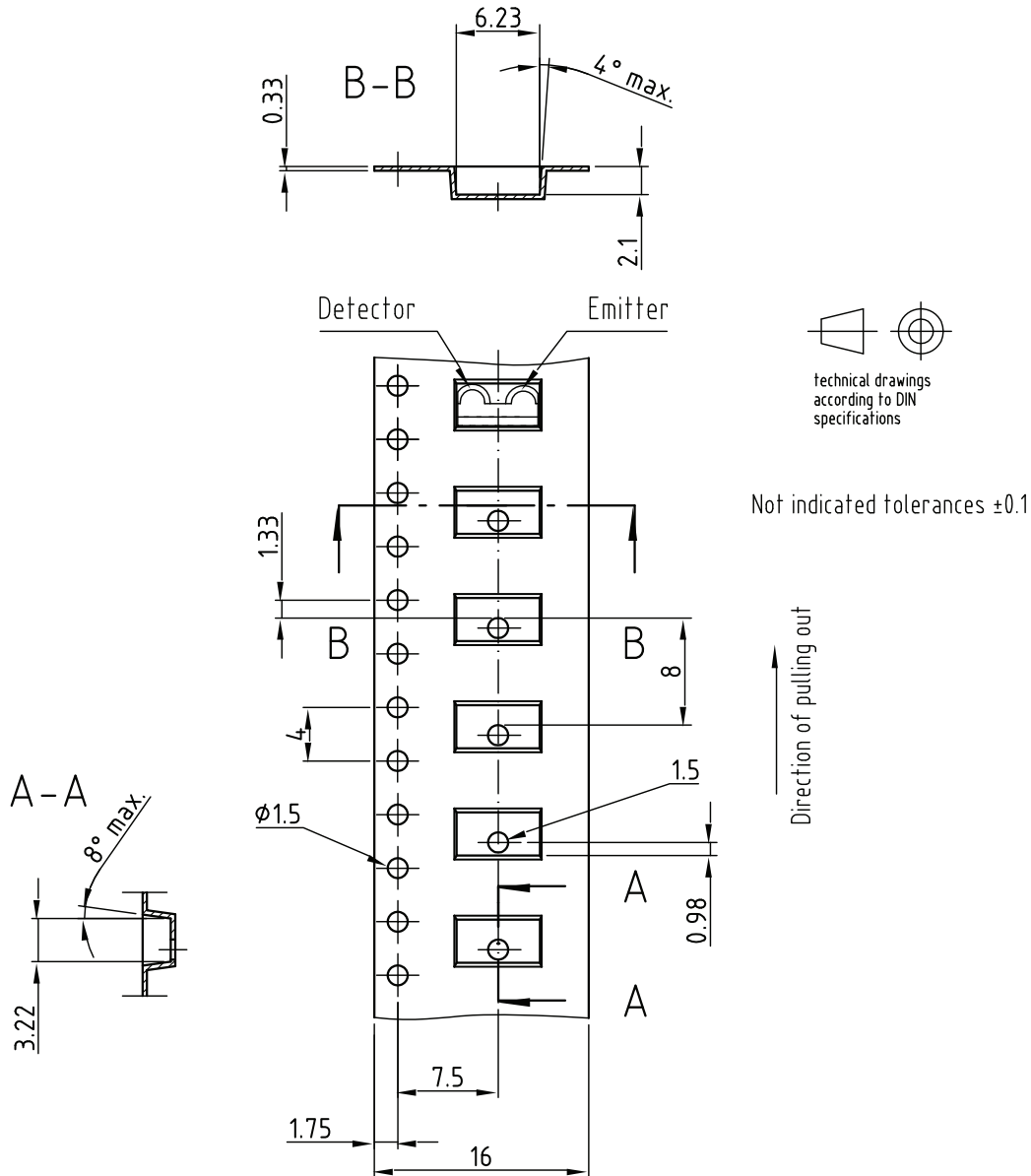

Fig. 4 - Soldering Footprints



TAPE DIMENSIONS FOR TR1 AND TR3 in millimeters



Drawing-No.: 9.700-5294.01-4

Issue: 1; 08.12.04

19613



TAPE DIMENSIONS FOR TT1 in millimeters

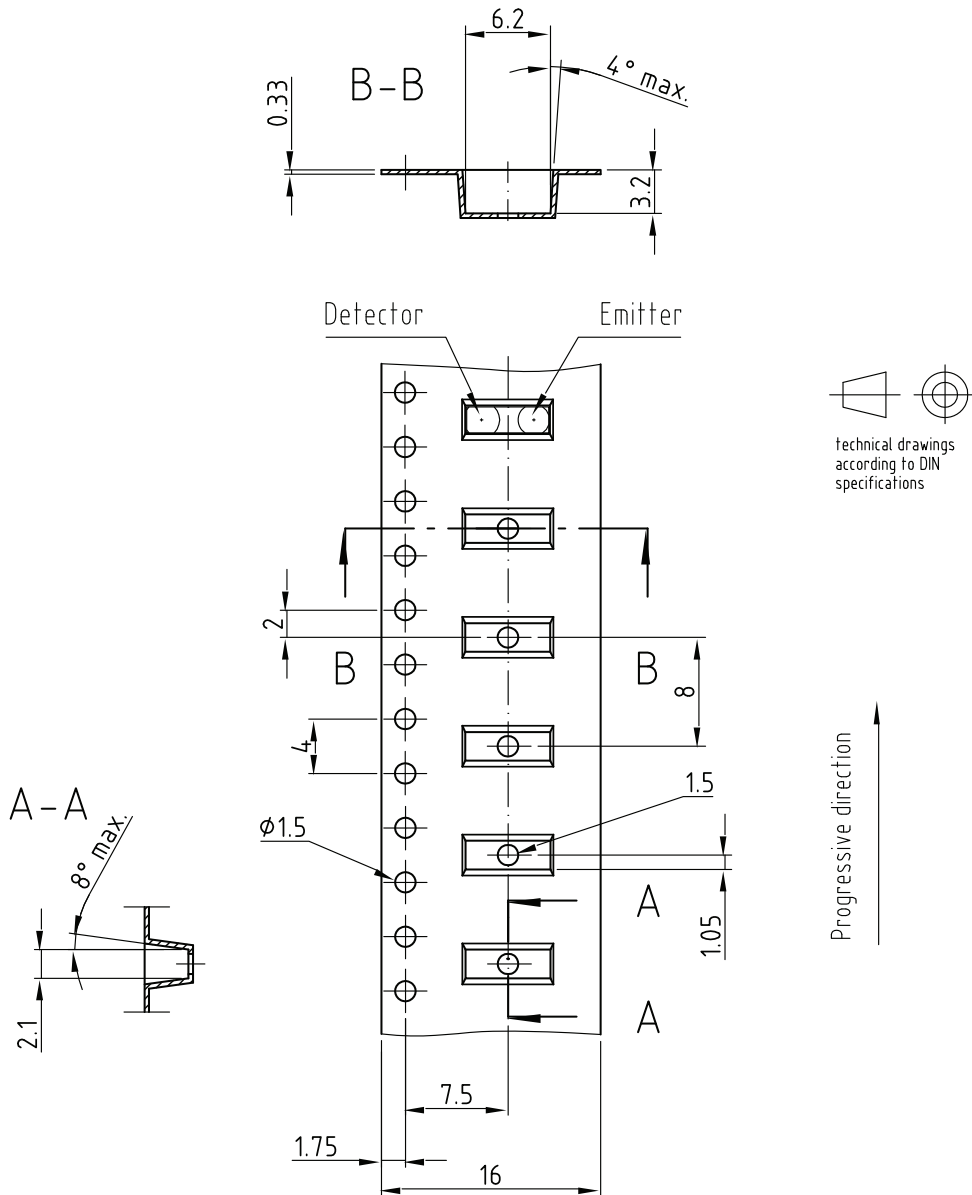

Drawing-No.: 9.700-5295.01-4
 Issue: 1; 08.12.04
 20416



REEL DIMENSIONS in millimeters

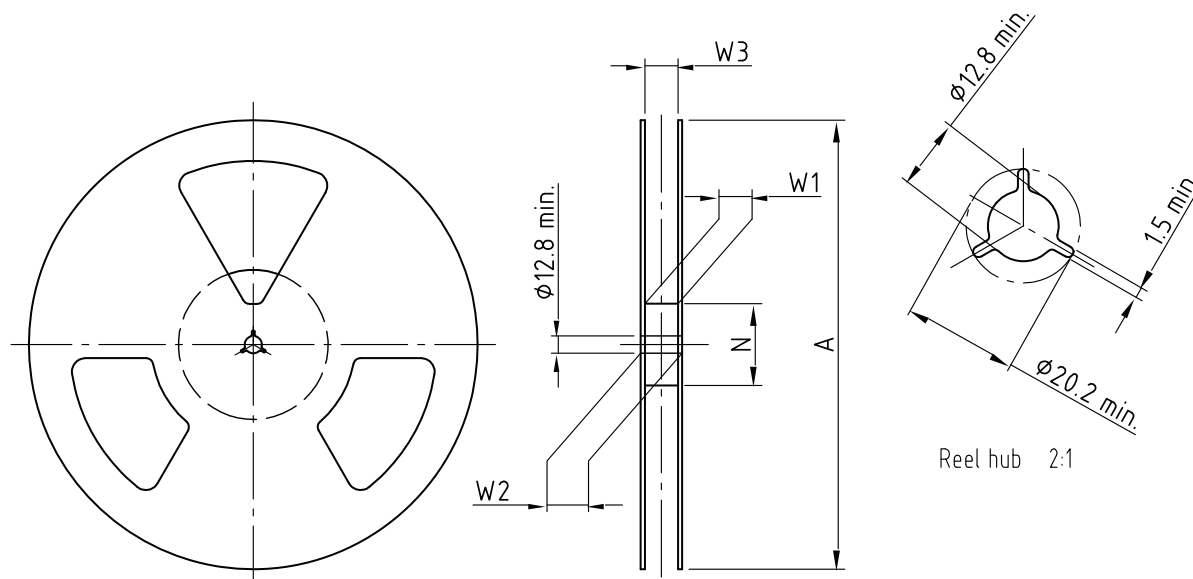

Drawing-No.: 9.800-5090.01-4
Issue: 1; 29.11.05
14017

Form of the leave open of the wheel is supplier specific.

Dimension acc. to IEC EN 60 286-3

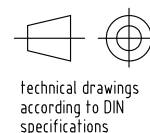

TAPING VARIANT	TAPE WIDTH (mm)	A MAX. (mm)	N (mm)	W ₁ MIN. (mm)	W ₂ MAX. (mm)	W ₃ MIN. (mm)	W ₃ MAX. (mm)
TT1 / TR1	16	180	60	16.4	22.4	15.9	19.4
TT3 / TR3	16	330	50	16.4	22.4	15.9	19.4

LEADER AND TRAILER DIMENSIONS in millimeters

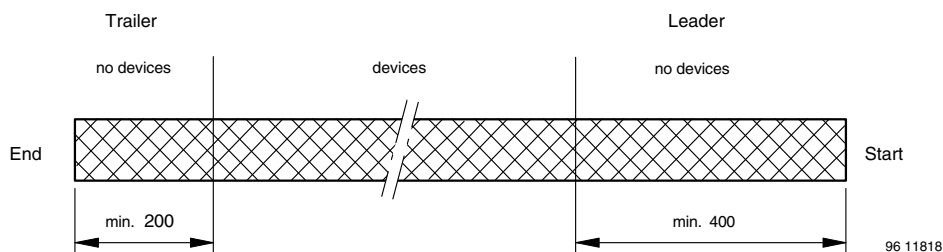

COVER TAPE PEEL STRENGTH

According to DIN EN 60286-3
0.1 N to 1.3 N
300 ± 10 mm/min.
165° to 180° peel angle

LABEL

Standard bar code labels for finished goods

The standard bar code labels are product labels and used for identification of goods. The finished goods are packed in final packing area. The standard packing units are labeled with standard bar code labels before transported as finished goods to warehouses. The labels are on each packing unit and contain Vishay Semiconductor GmbH specific data.



DRY PACKING

The reel is packed in an anti-humidity bag to protect the devices from absorbing moisture during transportation and storage.

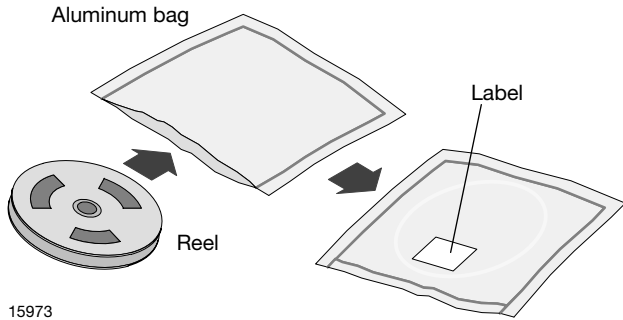

FINAL PACKING

The sealed reel is packed into a cardboard box.

RECOMMENDED METHOD OF STORAGE

Dry box storage is recommended as soon as the aluminum bag has been opened to prevent moisture absorption. The following conditions should be observed, if dry boxes are not available:

- Storage temperature 10 °C to 30 °C
- Storage humidity ≤ 60 % RH max.

After more than 72 h under these conditions moisture content will be too high for reflow soldering.

In case of moisture absorption, the devices will recover to the former condition by drying under the following condition:
 192 h at 40 °C + 5 °C / - 0 °C and < 5 % RH (dry air / nitrogen) or
 96 h at 60 °C + 5 °C and < 5 % RH for all device containers or
 24 h at 125 °C + 5 °C not suitable for reel or tubes.

An EIA JEDEC® standard J-STD-020 level 4 label is included on all dry bags.

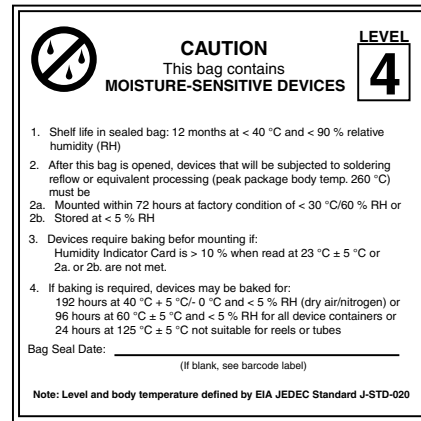

EIA JEDEC standard J-STD-020 level 4 label is included on all dry bags

OUTER PACKAGING

The sealed reel is packed into a pizza box.

CARTON BOX DIMENSIONS in millimeters				
<p>22127</p>				
ORDER CODE	BOXING	THICKNESS	WIDTH	LENGTH
TT3 / TR3	Pizza box (taping in reels)	50	340	340
TT1 / TR1	Pizza box (taping in reels)	32	190	190



VISHAY SEMICONDUCTOR GmbH STANDARD BAR CODE PRODUCT LABEL (finished goods)		
PLAIN WRITING	ABBREVIATION	LENGTH
Item-description	-	18
Item-number	INO	8
Selection-code	SEL	3
LOT-/serial-number	BATCH	10
Data-code	COD	3 (YWW)
Plant-code	PTC	2
Quantity	QTY	8
Accepted by	ACC	-
Packed by	PCK	-
Mixed code indicator	MIXED CODE	-
Origin	xxxxxxx+	Company logo
Long bar code top	Type	Length
Item-number	N	8
Plant-code	N	2
Sequence-number	X	3
Quantity	N	8
Total length	-	21
Short bar code bottom	Type	Length
Selection-code	X	3
Data-code	N	3
Batch-number	X	10
Filter	-	1
Total length	-	17

ESD PRECAUTION

Proper storage and handling procedures should be followed to prevent ESD damage to the devices especially when they are removed from the antistatic shielding bag. Electrostatic sensitive devices warning labels are on the packaging.

VISHAY SEMICONDUCTORS STANDARD BAR CODE LABELS

The Vishay Semiconductors standard bar code labels are printed at final packing areas. The labels are on each packing unit and contain Vishay Semiconductors specific data.





Disclaimer

ALL PRODUCT, PRODUCT SPECIFICATIONS AND DATA ARE SUBJECT TO CHANGE WITHOUT NOTICE TO IMPROVE RELIABILITY, FUNCTION OR DESIGN OR OTHERWISE.

Vishay Intertechnology, Inc., its affiliates, agents, and employees, and all persons acting on its or their behalf (collectively, "Vishay"), disclaim any and all liability for any errors, inaccuracies or incompleteness contained in any datasheet or in any other disclosure relating to any product.

Vishay makes no warranty, representation or guarantee regarding the suitability of the products for any particular purpose or the continuing production of any product. To the maximum extent permitted by applicable law, Vishay disclaims (i) any and all liability arising out of the application or use of any product, (ii) any and all liability, including without limitation special, consequential or incidental damages, and (iii) any and all implied warranties, including warranties of fitness for particular purpose, non-infringement and merchantability.

Statements regarding the suitability of products for certain types of applications are based on Vishay's knowledge of typical requirements that are often placed on Vishay products in generic applications. Such statements are not binding statements about the suitability of products for a particular application. It is the customer's responsibility to validate that a particular product with the properties described in the product specification is suitable for use in a particular application. Parameters provided in datasheets and / or specifications may vary in different applications and performance may vary over time. All operating parameters, including typical parameters, must be validated for each customer application by the customer's technical experts. Product specifications do not expand or otherwise modify Vishay's terms and conditions of purchase, including but not limited to the warranty expressed therein.

Hyperlinks included in this datasheet may direct users to third-party websites. These links are provided as a convenience and for informational purposes only. Inclusion of these hyperlinks does not constitute an endorsement or an approval by Vishay of any of the products, services or opinions of the corporation, organization or individual associated with the third-party website. Vishay disclaims any and all liability and bears no responsibility for the accuracy, legality or content of the third-party website or for that of subsequent links.

Vishay products are not designed for use in life-saving or life-sustaining applications or any application in which the failure of the Vishay product could result in personal injury or death unless specifically qualified in writing by Vishay. Customers using or selling Vishay products not expressly indicated for use in such applications do so at their own risk. Please contact authorized Vishay personnel to obtain written terms and conditions regarding products designed for such applications.

No license, express or implied, by estoppel or otherwise, to any intellectual property rights is granted by this document or by any conduct of Vishay. Product names and markings noted herein may be trademarks of their respective owners.